

# Residential Deck Drawings

## General Notes

1. All lumber shall be pressure treated for exterior use. All metal fasteners & hangers shall be G185 galvanized, stainless steel or otherwise compatible with the wood treatment. All bolts shall be 1/2" diameter, minimum.
2. All beams, joists, posts and decking shall be No. 2 Southern Pine, or better.
3. All beam splices and top rails shall occur at a post or otherwise on adequate bearing.
4. All footings shall be cast-in-place concrete with a min. 2500 psi compressive strength.
5. Guards are required at all areas where the deck/porch floor is greater than 30" above grade at any point.
6. Required guards shall be 36" tall (min.) and be constructed such that a 4" diameter object will not pass through.
7. Guard post spacing shall not exceed 6 ft. on center.
8. Required guards & handrails at stairs shall range from 34" to 38" vertically above the stair nosings.
9. Handrail ends, at the top and bottom, shall terminate into a post or be returned to a wall.
10. On stairs with closed risers, treads shall have a projected nosing ranging from 3/4" to 1-1/4". All treads and risers shall be equal.
11. The deck/porch floor shall be within 8-1/4" of the top of the door threshold.
12. Live Load Deflection: Joists & Beams- L/360  
Guards- L/240
13. Design Loads: Floor Live Load - 40 lbs./sf (min.)  
Wind Speed - 90 mph  
Soil Bearing Pressure - 3000 lbs./sf
14. Guards shall be designed for a 200 lb. concentrated load placed along the top rail in any direction, at any point.
15. This deck/porch is not designed for hot-tub or spa loading.
16. All exterior stairs & associated landings shall be illuminated.
17. Post size is based on the height of the deck floor above finished grade (at the highest point):  
0' to 8' high: 4x4, 4x6, 6x6  
8' to 10' high: 4x6, 6x6  
10' and up: 6x6 (required for multi-level decks too)
18. All separated beams shall receive full depth solid blocking at 24" on center, maximum spacing.
19. The actual field construction shall match the approved plans. All field changes and/or deviations require an Engineering Change approval.

## Framing/Footing Table

[1] Choose one floor joist size with the associated span, [2] Choose one floor beam size. Entire row applies.

Floor Joists <sup>a</sup>			Floor Beams <sup>b</sup>			Footing Size				1/2" Ledger Board Bolts
Choose Joist Size	Lumber Size	Max. Span [A]	Choose One Row	Lumber Size	Max. Span [B]	Single-Span Floor Joists		Multi-Span Floor Joists		Spacing
	(nominal)	(feet)		(nominal)	(feet)	min. dia. [C]	min. thick [D]	min. dia. [C]	min. thick [D]	
[ ]	2 x 6	8	[ ]	(2) 2 x 6	5	12	6	15	8	24
			[ ]	(2) 2 x 8	7	13	7	19	10	24
			[ ]	(2) 2 x 10	9	15	8	23	12	24
			[ ]	(2) 2 x 12	11	17	9	24	12	24
[ ]	2 x 8	10	[ ]	(2) 2 x 8	7	14	7	20	10	16
			[ ]	(2) 2 x 10	9	17	9	24	12	16
			[ ]	(2) 2 x 12	10	18	9	25	13	16
[ ]	2 x 10	13	[ ]	(2) 2 x 10	8	17	9	24	12	16
			[ ]	(2) 2 x 12	9	18	9	26	13	16
[ ]	2 x 12	16	[ ]	(2) 2 x 12	8	20	10	28	14	12

a. Choose one joist size and corresponding maximum span. All joists are spaced a maximum of 16" oc.

b. Choose one floor beam (entire row) that corresponds with the size of joist chosen.

## Beam to Post Connection Options

[3] Choose one beam to post connection option. [4] Choose one post size based on the height of the deck.

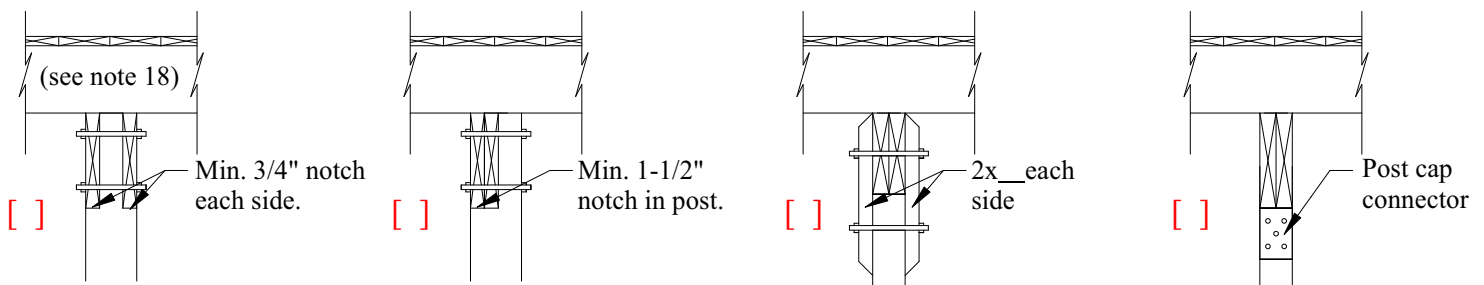

- |   |   |   |   |
|---|---|---|---|
| <input type="checkbox"/> 4x4 posts (up to 8')<br><input type="checkbox"/> 4x6 posts (up to 10')<br><input type="checkbox"/> 6x6 posts req'd over 10') | <input type="checkbox"/> 4x4 posts (up to 8')<br><input type="checkbox"/> 4x6 posts (up to 10')<br><input type="checkbox"/> 6x6 posts req'd over 10') | <input type="checkbox"/> 4x4 posts (up to 8')<br><input type="checkbox"/> 4x6 posts (up to 10')<br><input type="checkbox"/> 6x6 posts req'd over 10') | <input type="checkbox"/> 4x4 posts (up to 8')<br><input type="checkbox"/> 4x6 posts (up to 10')<br><input type="checkbox"/> 6x6 posts req'd over 10') |
|---|---|---|---|

<b>Property Owner:</b>	<b>Designer:</b>	<b>Contractor:</b>	Application No.
Name: _____	Name: _____	Name: _____	Sheet No.
Address: _____	Address: _____	Address: _____	1 of 4
Phone: _____	Phone: _____	Phone: _____	Residential Deck Drawings

# Foundation & Framing Plan

[5] Choose one span configuration:

- Single-Span
- Multi-Span

The actual field construction shall match the approved plans. All field changes and/or deviations require an Engineering Change approval.

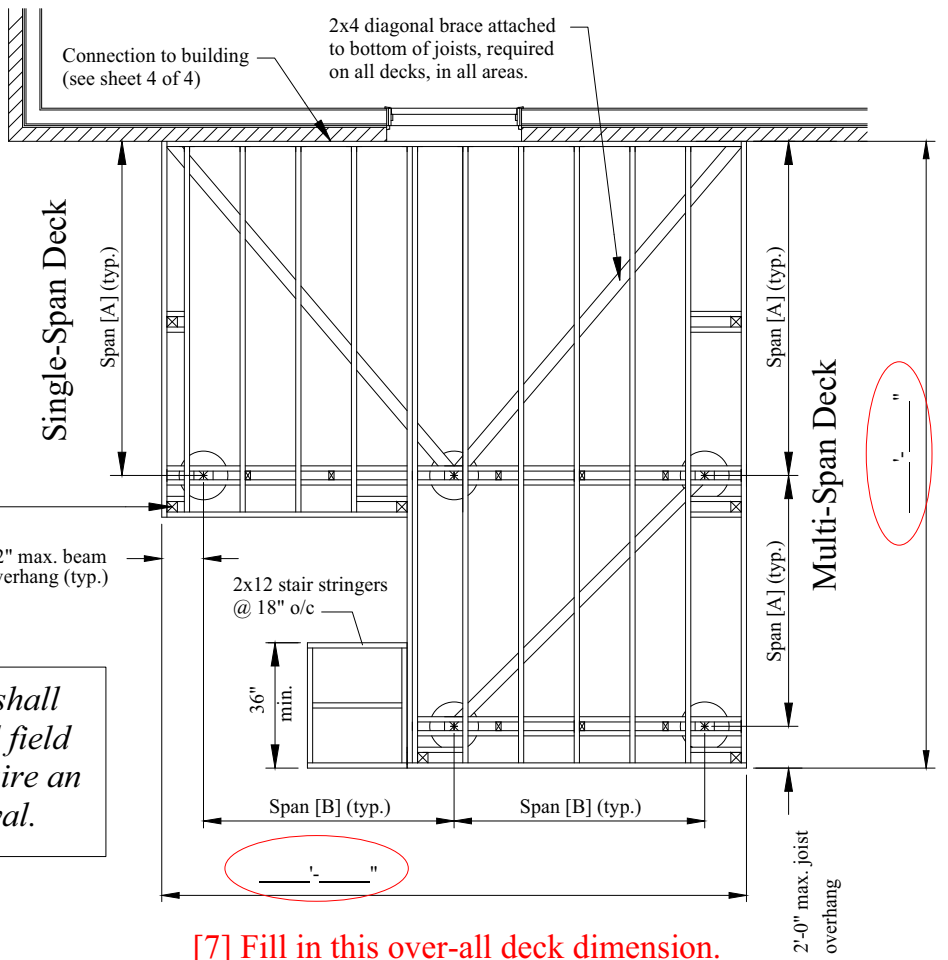

[6] Fill in this over-all deck dimension.

[7] Fill in this over-all deck dimension.

# Deck Finished Floor Plan

[8] Fill in the stair width in inches (36" min.).

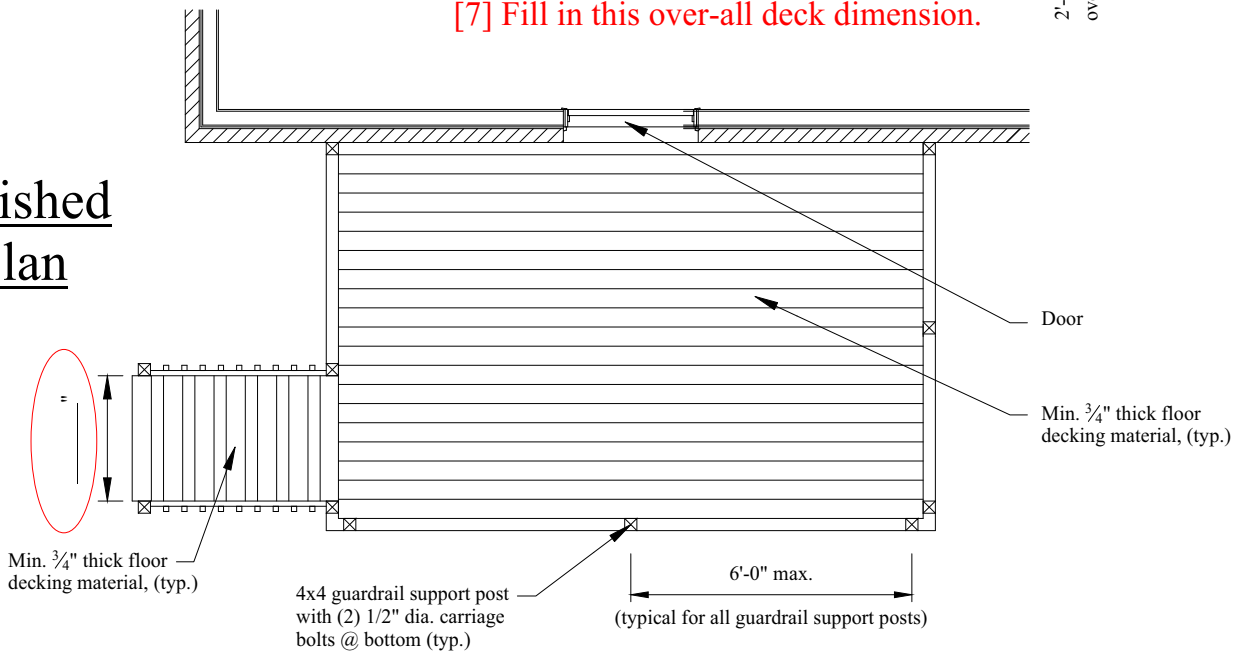

# Front Elevation View

[9] Using the answer to Step 5, fill in the footing diameter in inches.

[10] Choose a footing option:

- Post attached to top of concrete footing
- Post on top of buried concrete footing

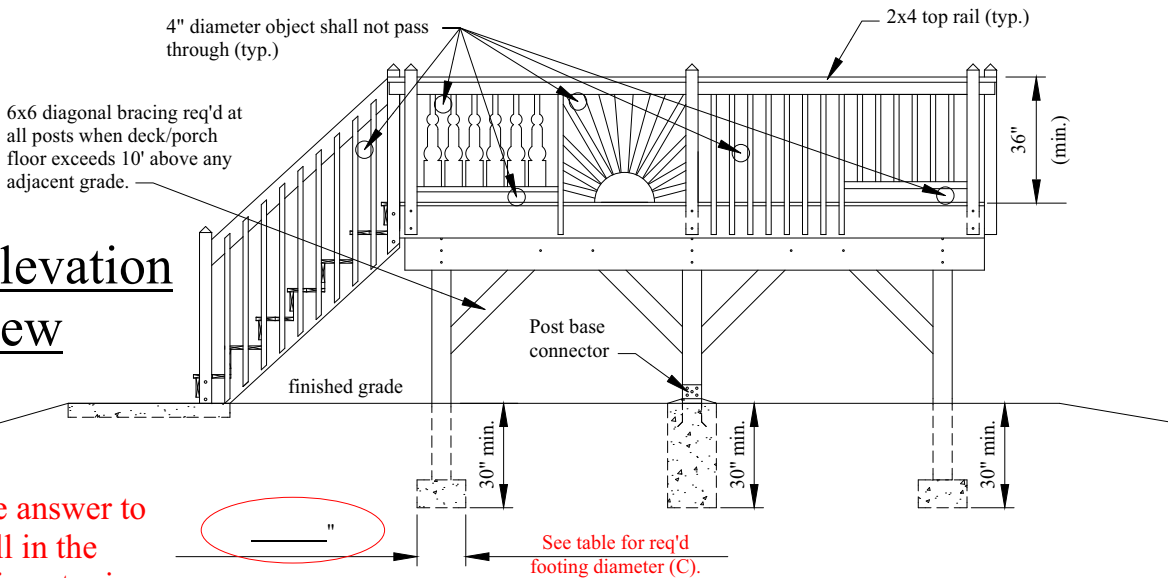

Application No.

Sheet No.

2 of 4

Residential Deck Drawings

## Left Side Elevation View

The actual field construction shall match the approved plans. All field changes and/or deviations require an Engineering Change approval.

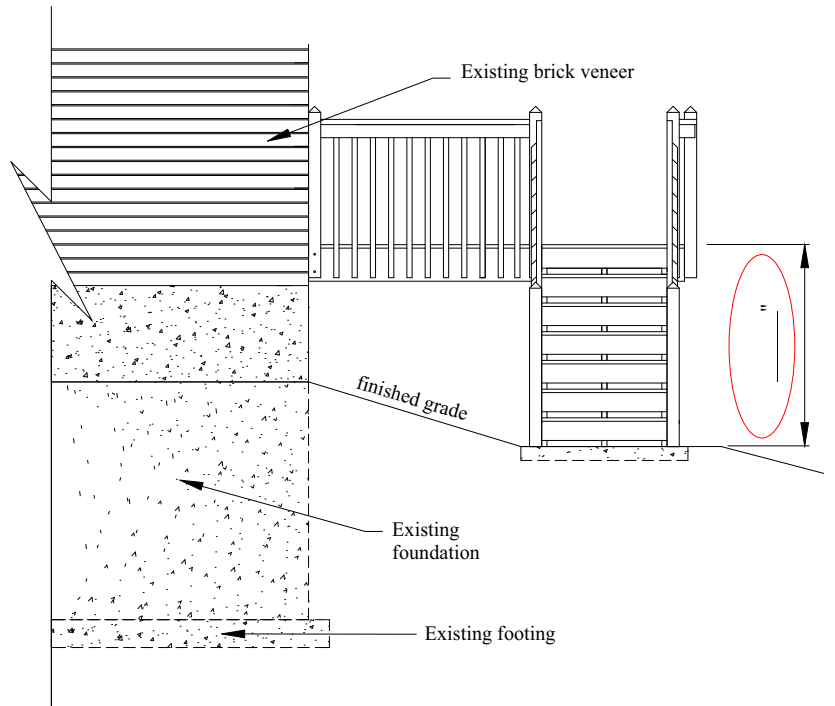

[11] Fill in the highest point above grade in inches.

## Stair Section View

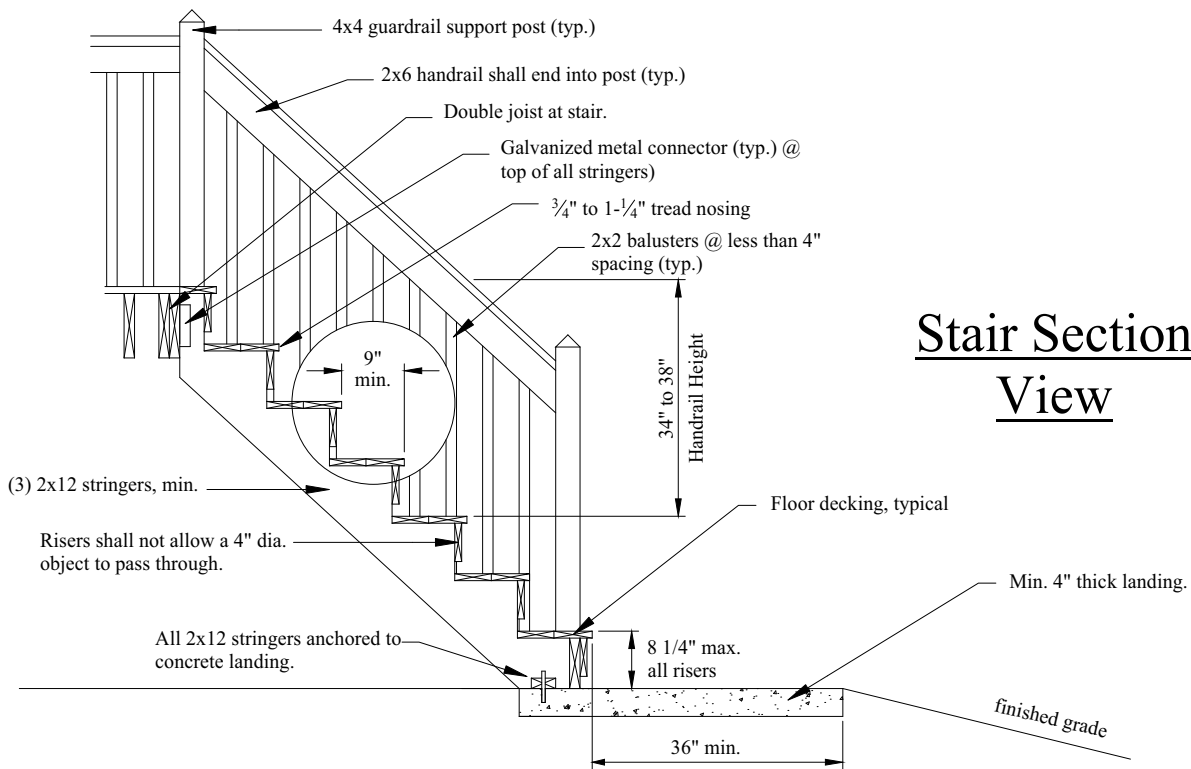

## Handrail Sections

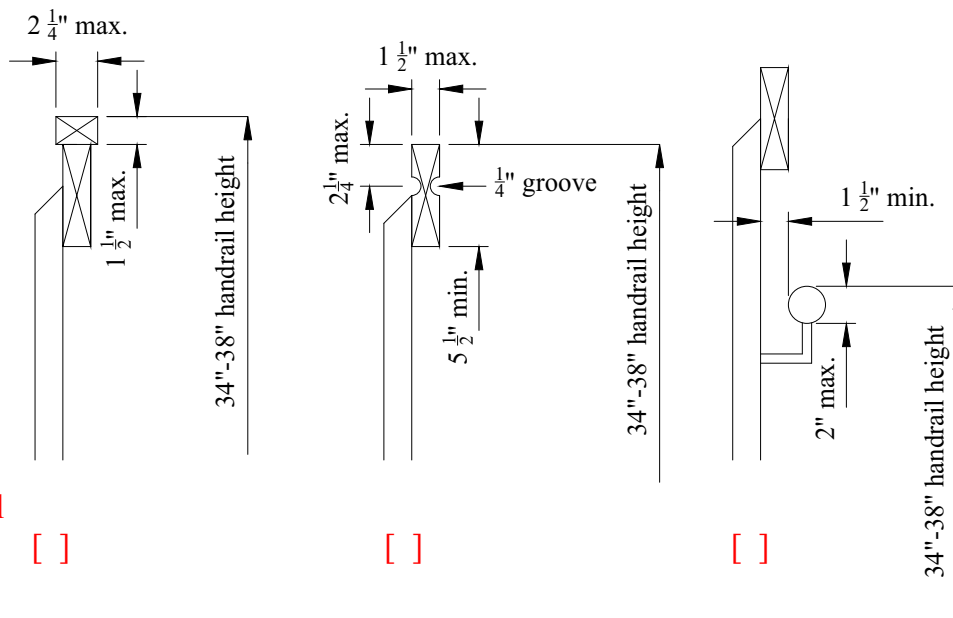

[12] Choose a handrail grip style:

[ ]

[ ]

[ ]

Application No.

Sheet No.

3 of 4

Residential Deck Drawings

# Post & Beam Detail

*The actual field construction shall match the approved plans. All field changes and/or deviations require an Engineering Change approval.*

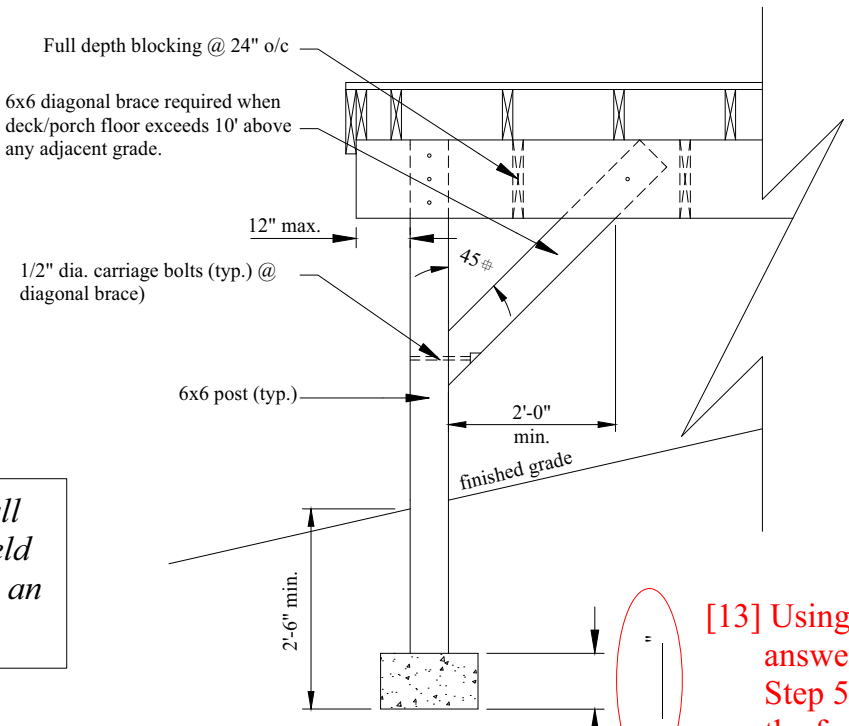

# Ledger Board Details

[14] Choose the ledger board detail that applies.

See table for req'd footing depth [D].

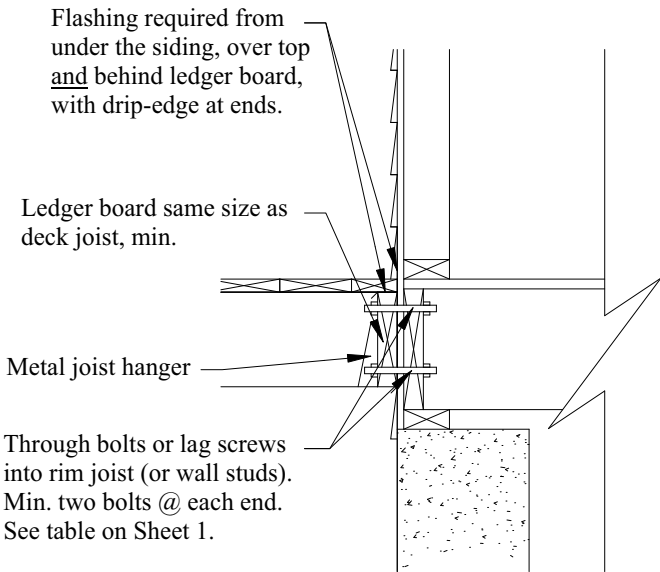

Siding Applications

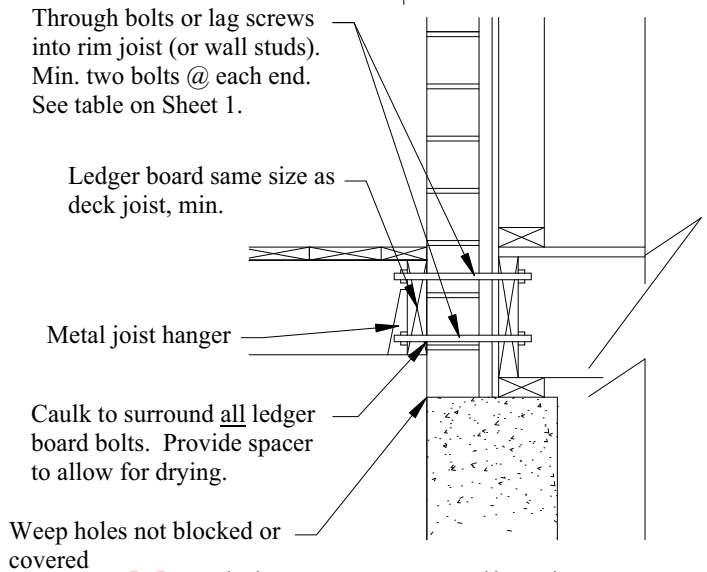

Brick Veneer Applications

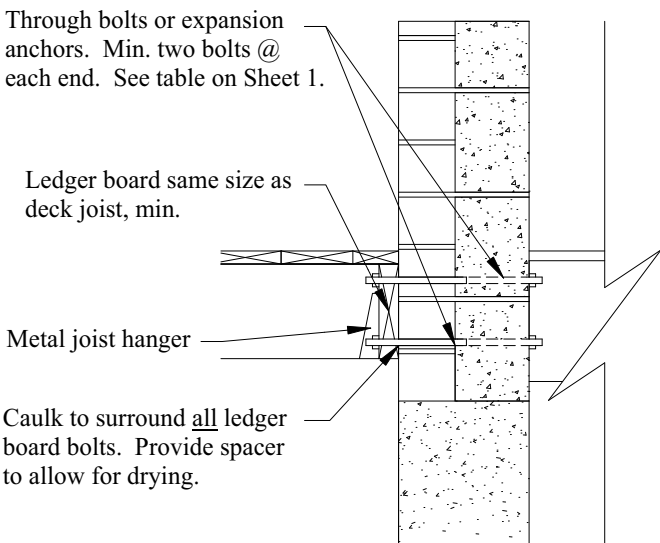

Brick/Block Applications

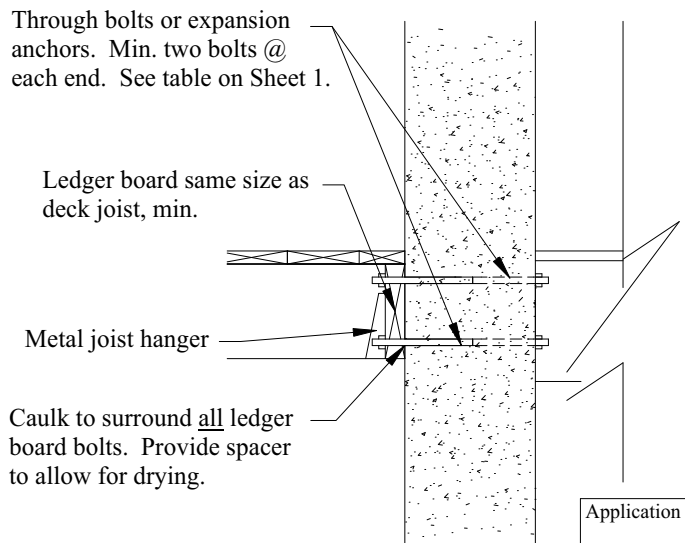

Concrete Applications

Application No.
Sheet No.
4 of 4
Residential Deck Drawings